

WARNINGS AND APPLICATION INSTRUCTIONS



SIDE PULL HR-1200 Hoist Ring Application / Assembly Instruction

- The Crosby side pull swivel hoist ring is designed to accept standard Crosby fittings to facilitate wider slings and quick attachment. In order to use the larger fittings, the load rating on the (shackle) fitting may be greater than the hoist ring frame. **Never exceed the Working Load Limit of the hoist ring frame.**
- Use swivel hoist ring only with a ferrous metal (steel, iron) or non-ferrous (i.e., aluminum) loads (workpiece). Do not leave threaded end of hoist ring in aluminum loads for long time periods due to corrosion.
- After determining the loads on each hoist ring, select the proper size hoist ring using the Working Load Limit ratings in Table 1 for UNC threads and Table 2 for Metric threads.
- For Subsea or Metric environment application, use the HR-1200 CT Series Hoist Ring Only.
- Drill and tap the workpiece to the correct size to a minimum depth of one-half the threaded shank diameter plus the threaded shank length.
- Drill and tap the workpiece to the correct size to a minimum depth of one-half the threaded shank diameter plus the threaded shank length.
- Install hoist ring to recommended torque with a torque wrench making sure the bushing flange is fully supported by the load (workpiece) surface. See rated load limit and bolt torque requirements imprinted on hoist ring body (See Table 1 or Table 2).
- Never use spacers between bushing flange and mounting surface.
- Always select proper lifting device for use with Swivel Hoist Ring (See Tables 1 & 2).
- Attach lifting device ensuring free fit to hoist shackle (See Figure 3).
- Apply partial load and check proper rotation and alignment of shackle. There should be no interference between load (workpiece) and hoist shackle (See Figure 1 and Figure 3).
- The Hoist ring should rotate into normal operating position, with shackle aligned with load as shown in Figure 3. If shackle is oriented as shown in Figure 4, **DO NOT LIFT.**
- **Special Note:** when a Hoist Ring is installed with a retention nut, the nut must have full thread engagement and must meet one of the following standards to develop the Working Load Limit (WLL).
 1. ASTM A-563 (A) Grade D Hex Thick (B) Grade DH Standard Hex
 2. SAE Grade 8 - Standard Hex

Hoist Ring Inspection / Maintenance

- Always inspect hoist ring before use.
- Regularly inspect hoist ring parts (Figure 2).
- For hoist rings used in frequent load cycles or on pulsating loads, the bolt threads should be periodically inspected by magnetic particle or dye penetrant.
- Do not use part showing cracks, nicks or gouges.
- Repair minor nicks or gouges to hoist frame by lightly grinding until surfaces are smooth. Do not reduce original dimension more than 10%. Do not repair by welding.

WARNING

- Loads may slip or fall if proper Hoist Ring assembly and lifting procedures are not followed.
- A falling load may cause serious injury or death.
- Install hoist ring bolt to torque requirements listed in tables.
- The side pull hoist ring frame will be only one part of a lifting system with several components (i.e., shackles and slings). Never exceed the Working Load Limit of the hoist ring frame.
- Do not use damaged slings or chain. For inspection criteria, see ASME B30.9.
- Read and understand these instructions before using hoist ring.
- Use only genuine Crosby parts as replacements.

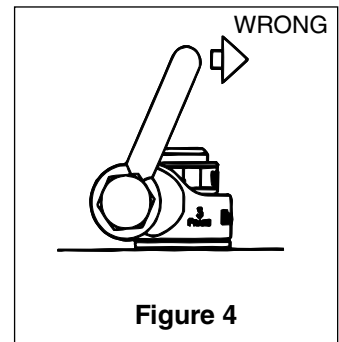
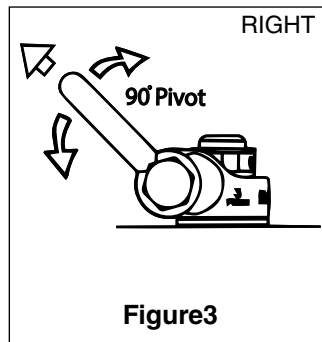
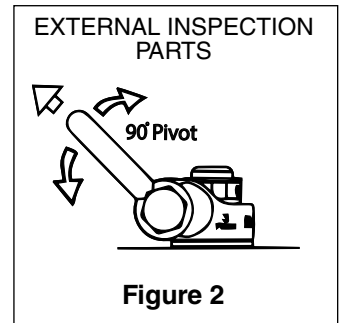
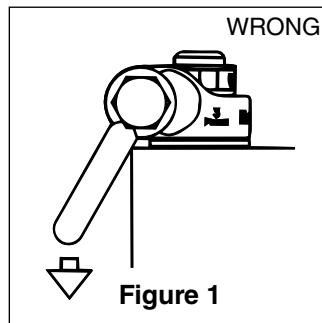

- Never use hoist ring that shows signs of corrosion, wear or damage.
- Never use hoist ring if components are bent or elongated.
- Always be sure threads on bolt and receiving tapped holes are clean, undamaged, and fit properly.
- Always check with torque wrench before using an already installed hoist ring.
- Always make sure there are no spacers (washers) used between bushing flange and the mounting surface. Remove any spacers (washers) and retorque before use.
- Always ensure free movement of shackle. The shackle should pivot 90° and the hoist ring should swivel 360° (See Figure 3).
- Always be sure total workpiece surface is in contact with hoist ring bushing mating surface. Drilled and tapped hole must be 90° to load (workpiece) surface.

OPERATING SAFETY

- Never exceed the capacity of the hoist ring, see Table 1 for UNC threads and Table 2 for Metric threads.
- When using lifting slings of two or more legs, make sure the forces in the legs are calculated using the angle from the horizontal sling angle to the leg and select the proper size swivel hoist ring to allow for the angular forces.

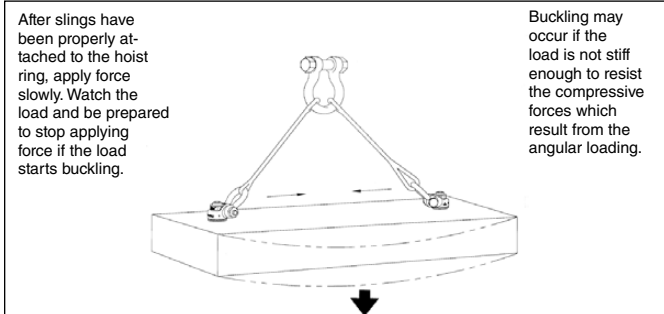
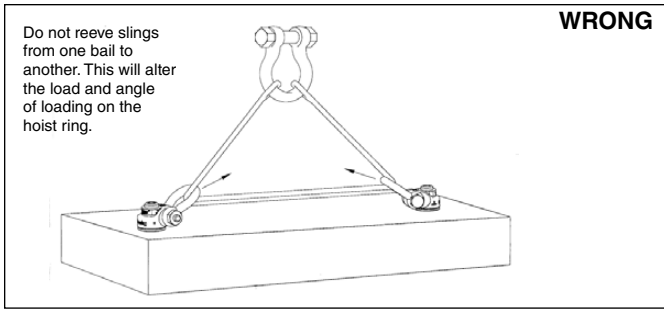

HR1200 UNC Threads TABLE 1

| Frame Size | Working Load Limit * (lbs.) | Hoist Ring Bolt Torque in Ft. Lbs. † | Bolt Size ‡ (in.) | Effective Thread Projection Length (in.) | Recommended Shackles | | | |
|------------|-----------------------------|--------------------------------------|-------------------|--|--|------------------------------------|------|---------------|
| | | | | | Red Pin® Shackles 209, 210, 213 215, 2130, 2150 (tons) | Red Pin® Web Shackles S-281 (tons) | | |
| 1 | 650†† | 7 | 5/16 - 18 x 1.5 | .59 | 1/2" - (2) | 2" - (3-1/4) | | |
| | 800†† | 12 | 3/8 - 18 x 1.5 | .59 | 5/8" - (3-1/4) | | | |
| 2 | 2000 | 28 | 1/2 - 13 x 2.0 | .71 | 5/8" - (3-1/4) | 2" - (3-1/4) | | |
| | 2000†† | 28 | 1/2 - 13 x 2.5 | 1.21 | 3/4" - (4-3/4) | 1-1/2" - (4-1/2) | | |
| | 3000 | 60 | 5/8 - 11 x 2.0 | .71 | | | | |
| | 3000†† | 60 | 5/8 - 11 x 2.75 | 1.46 | | | | |
| 3 | 5000 | 100 | 3/4 - 10 x 2.75 | 1.46 | 7/8" - (6-1/2) | 2" - (6-1/4) | | |
| | 5000†† | 100 | 3/4 - 10 x 3.5 | 1.63 | | | | |
| | 6500 | 160 | 7/8 - 9 x 2.5 | .90 | | | | |
| | 6500†† | 160 | 7/8 - 9 x 3.5 | 1.65 | | | | |
| | 8000 | 230 | 1 - 8 x 3.0 | 1.15 | | | | |
| | 8000†† | 230 | 1 - 8 x 4.0 | 2.15 | | | | |
| 4 | 14000 | 470 | 1-1/4 - 7 x 4.5 | 2.22 | 1" - (8-1/2) | 3" - (8-1/2) | | |
| | | | | | 1-1/8" - (9-1/2) | | | |
| | | | | | 1-1/4" - (12) | | | |
| 5 | 17200 | 800 | 1-1/2 - 6 x 6.5 | 2.98 | 1-3/8" - (13-1/2) | — | | |
| | | | 29000 | 1100 | 2 - 4-1/2 x 6.5 | | 2.98 | 1-1/2" - (17) |
| | | | | | | | | 1-3/4" - (25) |

HR1200M Metric Threads TABLE 2

| Frame Size | Working Load Limit * (kg) | Hoist Ring Bolt Torque Nm † | Bolt Size ‡ (mm) | Effective Thread Projection Length (mm) | Recommended Shackles | |
|------------|---------------------------|-----------------------------|------------------|---|--|------------------------------------|
| | | | | | Red Pin® Shackles 209, 210, 213 215, 2130, 2150 (tons) | Red Pin® Web Shackles S-281 (tons) |
| 1 | 300 | 10 | M8 x 1.25 x 40 | 16.9 | 1/2" - (2) | 2" - (3-1/4) |
| | 400 | 16 | M10 x 1.5 x 40 | 16.9 | 5/8" - (3-1/4) | |
| 2 | 1000 | 31 | M12 x 1.75 x 50 | 17.2 | 5/8" - (3-1/4) | 2" - (3-1/4) |
| | 1400 | 81 | M16 x 2.00 x 60 | 27.2 | 3/4" - (4-3/4) | 1-1/2" - (4-1/2) |
| 3 | 2250 | 136 | M20 x 2.50 x 75 | 28.1 | 7/8" - (6-1/2) | 2" - (6-1/4) |
| | 3500 | 312 | M24 x 3.00 x 80 | 33.1 | | |
| 4 | 6250 | 637 | M30 x 3.5 x 120 | 65.1 | 1" - (8-1/2) | 3" - (8-1/2) |
| | | | | | 1-1/8" - (9-1/2) | |
| | | | | | 1-1/4" - (12) | |
| 5 | 7750 | 1005 | M36 x 4.0 x 150 | 60.6 | 1-3/8" - (13-1/2) | — |
| | 10000 | 1005 | M42 x 4.5 x 160 | 70.6 | 1-1/2" - (17) | |
| | 13000 | 1350 | M48 x 5.0 x 160 | 70.6 | 1-3/4" - (25) | |
| | | | | | | |

Designed to be used with Ferrous workpiece only

* Ultimate load is 5 times the Working Load Limit. Individually proof tested to 2-1/2 times the Working Load Limit.

† Tightening torque values shown are based upon threads being clean, dry and free of lubrication.

†† Long bolts are designed to be used with soft metal (i.e., aluminum) workpiece. While the long bolts may also be used with ferrous metal (i.e., steel & iron) workpieces, short bolts are designed for ferrous workpieces only.

‡ Bolt specification is a Grade 8 Alloy socket head cap screw to ASTM A574. All threads are UNC - 3A.

‡‡ Bolt specification is a Grade 12.9 Alloy socket head cap to DIN 912. All threads are metric (ASME/ANSI B18.3.1m).